



# I-5

## SEQUENTIAL COMMAND 4 OUTPUTS

The I-5 module is a sequential command with 4 relay outputs. With each impulse, relays will be connected one after one, and disconnecting the previous one. The sequence could be produce by external impulses or thanks to an internal oscillator. The oscillator is adjusted with a potentiometer inserted in the PCB. It includes reset output, protection against polarity inversion, indicator output led and terminals to connect it.

**Don't forget to read all the information sheet in order to obtain a perfect operating of the module.**

### TECHNICAL CHARACTERISTICS.

Voltage .....	12 V. D.C.
Minimum Consumption .....	50 mA.
Maximum Consumption .....	60 mA.
External Clock - input maxi. Frequency .....	25 Hz.
Internal Clock - Mini. Connection time by relay .....	0,3 Sec.
Internal Clock - Maxi. Connection time by relay .....	10 Sec.
Maximum Output Load By Relay .....	5 A.
Protection Against Polarity Inversion .....	Yes
Sizes .....	110 x 78 x 30 mm.

### OPERATING.

**POWER SUPPLY.** The I-5 circuit had to be supplied by a 12 VDC power supply.

Then, we recommended you the FE-2 power supply which has been developed to perfectly answer to the circuit needs or a 12 V batteries for mobile applications. Install a fuse and a switch as it is indicated in the drawing. Both are obligatory to guarantee a correct protection of the module as well as for your own safety as it is required by the "CE" marking.

Connect the positive of the power supply to the positive terminal indicated in the wiring map, then connect also the negative of the power supply to the negative terminal indicated in the circuit. **Verify** that the assembly has been correctly done.

**OPERATING.** See the general wiring map. The module has a switch indicated as INT-1. Thanks to this switch you could select between automatic operating (controlled by the internal oscillator) and manual operating which be externally inserted.

**Regarding manual operating.** you have to place (in the switch INT-1) the contact N°1 in ON position and the contact N°2 in OFF position. Do not place permanently both contact in the same position to avoid to damage the module. See the drawing.

Connect a push button to the terminal indicated as impulses input (See General wiring map). If you have to connect a clock signal from an other apparatus, you have to respect their polarity and verify that it is a 12 VDC signal.

When the push button is installed, after each pressure relay will be activated one after one, and disconnecting the previous one.

**Regarding automatic operating.** you have to place (in the switch INT-1) the contact N°1 in OFF position and the contact N°2 in ON position. Do not place permanently both contact in the same position to avoid to damage the module. See the drawing.

Adjust the speed using the potentiometer inserted in the PCB to adjust the frequency. After each pressure relay will be activated one after one, and disconnecting the previous one.

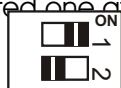

**Manual Operating**  
External Clock



**Automatic Operating**  
Internal Clock

**RESET.** See the general wiring map. Connect a push button to the terminal indicated as "Reset". Each time you

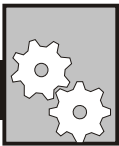

## GENERAL WIRING MAP.

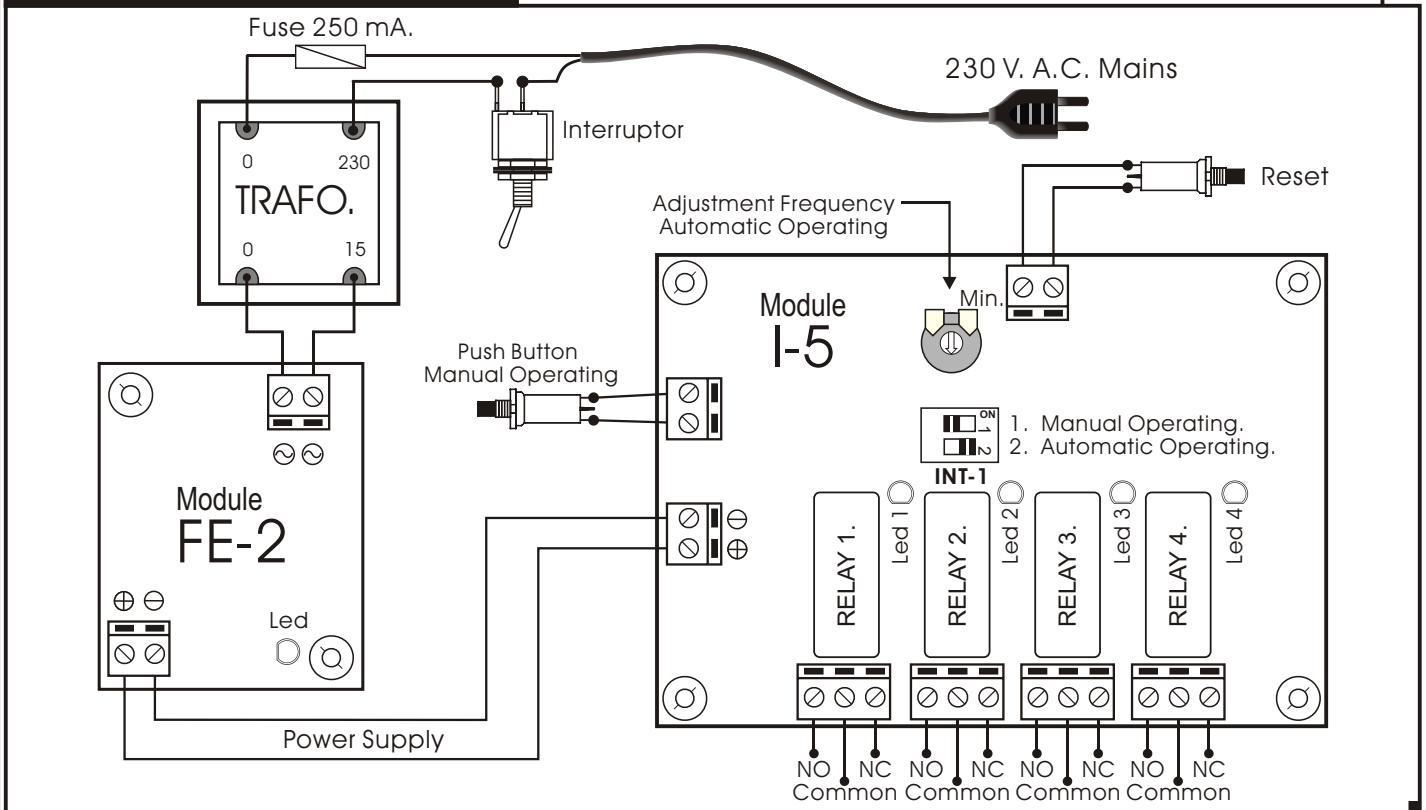

## OUTPUT. CONNECTION OF THE LOAD.

press this push button and independently of the activated relay, the module will come back at the beginning of the sequence (to the first relay) until you stop to press the "reset" push button.

**OUTPUT. CONNECTION OF THE LOAD.** The output Module (I-5) is controlled by a relay, allowing any load until 5 A. as maximum consumption. The relay has 3 output terminals the normally open at quiescent (NO), the normally closed at quiescent (NC) and the common. The operating of this mechanism is the same as a switch with two (2) terminals NO and common, if you wish that the output will be activated during the timer, or

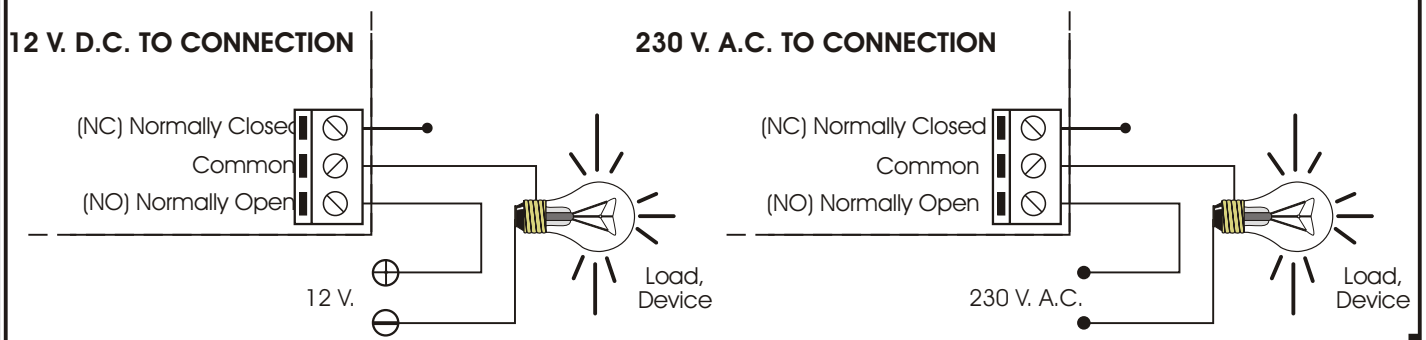

## TECHNICAL SUPPORT AND INFORMATION.

For any questions or more information:

**By Fax.** (24h.) +34.3. 432.29.95

**By Mail:** C/ Quetzal, 17-21, Entlo. 2º (08014) BARCELONA - SPAIN.

**By E-Mail:** [cebek@sakma.es](mailto:cebek@sakma.es)

**Keep you invoice.** For any repairing could you send this with module. Else, the module will lost the warranty.

**MORE 300  
MODULES.**

All the module's CEBEK have **3 years of total warranty** in technical repairing, and spares from the date of buy.

CEBEK is trade make of FADISEL S.L. more than 300 module's are available in stock for any purpose **request our CATALOGUE**, or visit our Web.

[Http://www.sakma.com/CEBEK](http://www.sakma.com/CEBEK)

**WARRANTY**

**3  
YEARS**