



I-36

DELAYING TIMER FROM 1 Sec. to 3 Min.

When the power supply is connected, the I-36 circuit will start a delay timing adjustable from 1 sec. up to 3 min. thanks to a potentiometer inserted in the PCB. After the adjusted delaying time, the output will be continuously activated up to the power supply disconnection.

The I-36 module could be activated supplying voltage and/or closing its contacts using a push button. It includes a protection against polarity inversion, an indicator operating led, connector to withdraw the exterior potentiometer and terminals to connect it.

TECHNICAL CHARACTERISTICS.

Voltage.....	12 VDC.
Minimum Consumption.....	15 mA.
Maximum Consumption.....	70 mA.
Minimum Time.....	1 Sec.
Maximum Time.....	3 Min.
Maximum Load At The Relay.....	5A
Operating Indicator Led.....	Yes
Protection Against Inversion Polarity	Yes
Sizes.	76 x 44 x 30 mm.

OPERATING.

POWER SUPPLY. The I-36 circuit had to be supplied by a 12 VDC power supply well filtered. Do not use suppliers or rectifiers because they allow interference disturbing the circuit operating.

Then, we recommended you the FE-2 power supply which has been developed to perfectly answer to the circuit needs (or 12V battery for mobile application). Connect the positive of the power supply to the positive terminal indicated in the wiring map, then connect also the negative of the power supply to the negative terminal indicated in the circuit. **Verify** that the assembly has been correctly done.

TIMING. To adjust the delaying time before the output's activation use the potentiometer inserted in the PCB. Start the operating test placing the potentiometer at the minimum (after you could place it according to your need). When the time is selected, connect the power supply of the I-36 module, then the module will be activated and the timing start. At the end of the delaying time, the led will light and the relay is activated connecting the output. To stop the relay activation you have to stop to supply the module.

OUTPUT. CONNECTION OF THE LOAD. The output Module (I-36) is controlled by a relay, allowing any load until 5 A. as maximum consumption. The relay has 3 output terminals the normally open at quiescent (NA), the normally closed at quiescent (NC) and the common. The operating of this mechanism is the same as a switch with two (2) terminals NA and common, if you wish that the output will be activated during the timer, or between the NC and the common to obtain the reverse operating.

In the Output connection paragraph, you could appreciate the typical connection for a devices operating at 12 VDC and to operate at 220 VAC.

The installation is between the Common and NA, where the device or load that you wish to control will be activated during the operating time.

To obtain the inverse operating, substitute in the connection the NA by the NC.

START WITH A PUSH BUTTON. The I-36 module could be activated supplying voltage and/or closing its contacts using a push button (as delivered from our factory). To use the I-36 with a push button, you have to withdraw the **C3** capacitor indicated in the general wiring map and in the PCB.

Then, connect a quality push button to the terminals of the J2 jumper (also indicated in the general wiring map). If the wiring distance is superior than 20 cm., you have to use shielded cable.

Press the push button and the delaying time will start and after activating at the end the relay. To deactivate it you have to disconnect the power supply.



TIMERS

Rev. Full9807

I-36

OPERATING.

EXTERIOR INSTALLATION OF THE POTENTIOMETER. If you wish to withdraw or substitute the potentiometer inserted into the P.C.B by an exterior one, firstly you had to suppress the already soldered potentiometer. Then, and as it is indicated in the drawing, connect the cable between the element or jumper indicated as "J1" and new potentiometer. Both potentiometers have to be lineal and offering 2M2.

GENERAL WIRING MAP.

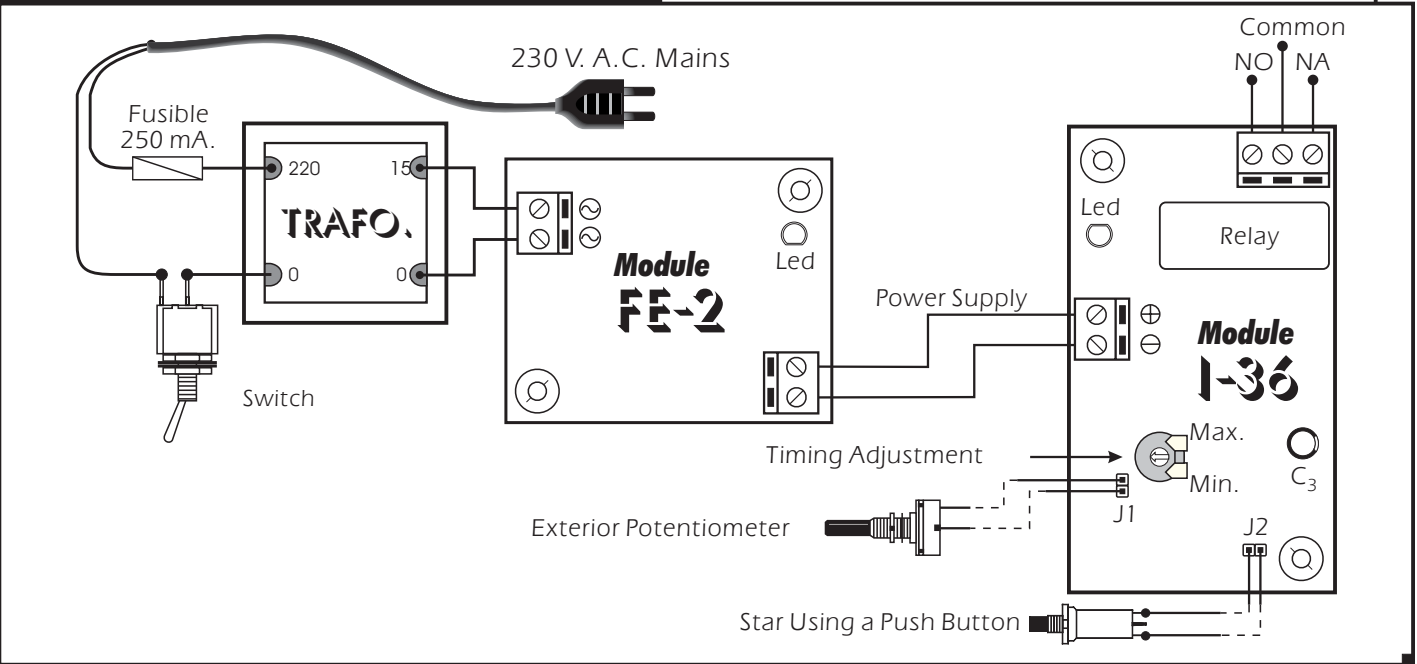

OUTPUT. CONNECTION OF THE LOAD.

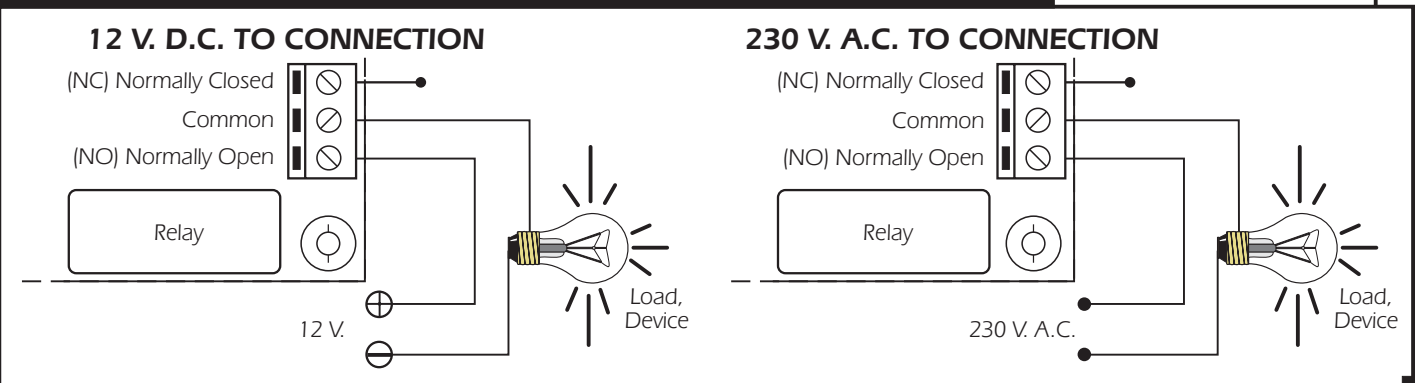

TECHNICAL SUPPORT AND INFORMATION.

For any questions or more information:

By E-Mail: sat@cebek.com

By Mail: C/ Quetzal, 17-21, Entlo. 2º (08014) BARCELONA - SPAIN.

Keep you invoice. For any repairing could you send this with module. Else, the module will lost the warranty.

**MORE 300
MODULES.**

All the module's CEBEK have **3 years of total warranty** in thechnical repairing, and spares from the date of buy.

CEBEK is trade make of FADISEL S.L. more than 300 module's are available in stock for any purpose **request our CATALOGUE**, or visit our Web.

[Http://www.cebek.com](http://www.cebek.com)

WARRANTY

**3
YEARS**