



# R-5

## 6 - 16 V. DC 6 A. SPEED CONTROLLER

The R-5 module is a speed controller for DC motors, supplied from 6 up to 16 V. DC with a maximum consumption of 6 A. The speed adjustment is done thanks to the variation of the duty cycle. The module could also control other resistive loads like resistors. It includes potentiometer to adjust the minimum as well as connection terminals.

### TECHNICAL CHARACTERISTICS.

Voltage. ....	From 6 up to 16 V. DC.
Output type . ....	Transistor.
Maximum operating Consumption. ....	6 A.
Maximum Voltage fall . ....	1.25 V.
Operating Frequency. ....	100-140 Hz.
Sizes. ....	68 x 65 x 44 mm.

### OPERATING.

**POWER SUPPLY.** The module is supplied from the same power supply than the motor. To obtain a correct operating mode, we recommend you to us power supply correctly filtered. Seeing the General Wiring map, install a fuse and a switch has it is indicated on the schedule. Both are necessary for the module's protection as well as for your own safety, as it is required by the "CE" regulations. Connect the positive of the power supply to the positive terminal indicated in the wiring map, then connect the negative of the power supply to the negative terminal indicated in the circuit. **Verify that the assembly is correct.**

**OUTPUT CONNECTION. LOAD.** The module only admit resistive loads. Do never try to control inductive loads like neons, halogen lamps, transformers, etc,...

To connect the output you have to connect the motor or load to the terminal indicated on the General Wiring Map. Respect the polarity mentioned on the schedule.

**OPERATING.** When the connection between output and input is done, you could activate the switch to supply the module, and thanks to the potentiometer you could adjust the speed. It is very important to start the motor at the maximum speed, then you could adjust it according to your needs.

**MINIMUM SPEED ADJUSTMENT.** If you wish to adjust the minimum speed you have to put at the minimum the speed adjustment potentiometer. Then you could adjust the variable resistor from the minimum till the motor stop.

**INSTALLATION.** Do not install the module under bad weather. Install it into a metallic enclosure well ventilated. Indeed, during the operating, the module will dissipate a high heat and for this reason, a bad ventilation will reduce its yields and could be damage it.

As the module uses the Switch Mode speed adjustment technology, it could generate interferences on other devices. For this reason, you have to install a mains filter between 230 V AC input and transformer of the power supply as it is indicated on the schedule.



# SPEED CONTROLLER

Ref. FULL9704

# R-5

## GENERAL WIRING MAP.

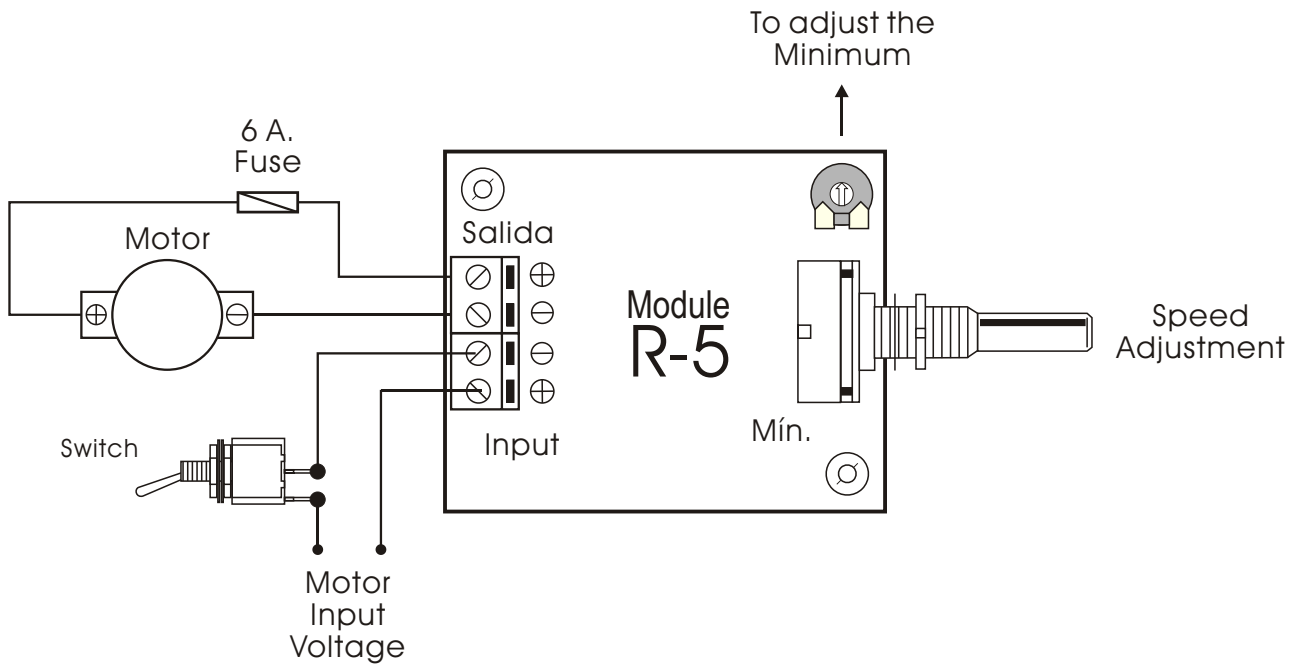

## HOW TO INSTALL A MAINS FILTER.

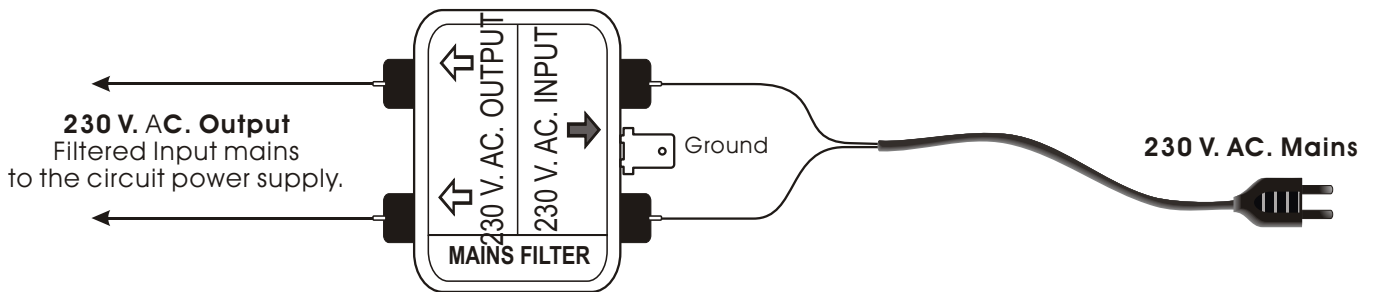

## TECHNICAL CONSULTATIONS.

If you have any doubt, you could contact your wholesaler or our Technical Department.  
 - Via E-Mail, [sat@cebek.com](mailto:sat@cebek.com) | by mail P.O Box 23455 - 08080 BARCELONA - SPAIN.

**MORE 300  
MODULES.**

All the module's CEBEK have **3 years of total warranty** in thechnical repairing, and spares from the date of buy.

CEBEK is trade make of FADISEL S.L. more than 300 module's are available in stock for any purpose **request our CATALOGUE**, or visit our Web. [Http://www.cebek.com](http://www.cebek.com)

**WARRANTY**

**3  
YEARS**