



# R-10

## 2 CV (1.500W) SPEED REGULATOR

The R-10 module is a speed regulator for AC monophase engine up to 1.500 W.(specially recommended for power-drill, vacuum-cleaner, etc...

The module could support others resistive loads as heater, resistors,. It includes potentiometer to adjust the minimum as well as connection terminals.

### TECHNICAL CHARACTERISTICS.

Operating Voltage.....	230 V. A.C.
Output.....	Triac.
Maximum Output Power.....	1.500 Watts (2 CV).
Adjustment Margin.....	From 33 up to 98 %.
Minimum Operating Voltage.....	90 V.
Hysteresis Level.....	Inferior than 3 %.
Protection Against Interferences.....	Yes.
Sizes.....	60 x 55 x 25 mm.

### OPERATING.

**MODULE'S SUPPLY.** The R-10 circuit is supplied by 230 VAC. To obtain a correct operating, you have to insulate the module from parasites using a filter for mains (230 VAC). See the paragraph "How to install the Filter". Seeing general wiring map, you have to use correct plug and cable to connect it to the 230 VAC input terminal. Install a fuse and a switch (both are necessary for the module and your own safety as you could note in the EC regulations). Then, verify that the assembly is correct.

Before to connect the switch to supply the module you have to do all indicated connections. **Don't forget that in the circuit you have 230 VAC.** For this reason you have to be very careful.

**LOAD. OUTPUT CONNECTION.** The module only accept universal engines. Do not control inductive loads as fluorescent, halogen lamps, transformers, etc...

To connect the output, connect the engine or load to the terminal indicated in the "General wiring map".

**OPERATING.** When the input and output connections are done and verified you could activate the switch to supply the module and thanks to the potentiometer you could adjust the engine's speed.

**MINIMUM SPEED ADJUSTMENT.** If you wish to adjust the minimum speed of the engine, you have to firstly put the potentiometer at the minimum. Then, you have to regulate the variable resistor for the minimum adjustment up to stop the engine.

**INSTALLATION.** Don't install the module at the bad weather, even if it is protected. For the installation you have to use a metallic enclosure well ventilated. As the circuit will reach a high temperature, a bad ventilation will reduce its characteristics and/or damage it.

The module operating with a triac could generate interferences to other apparatus.If it is correct, you have to install a mains filter to the 230 VAC input (see "How to install a filter" paragraph).

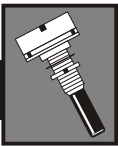

# SPEED REGULATORS.

Ref. FULL9814\_Ang.

# R-10

## GENERAL WIRING MAP.

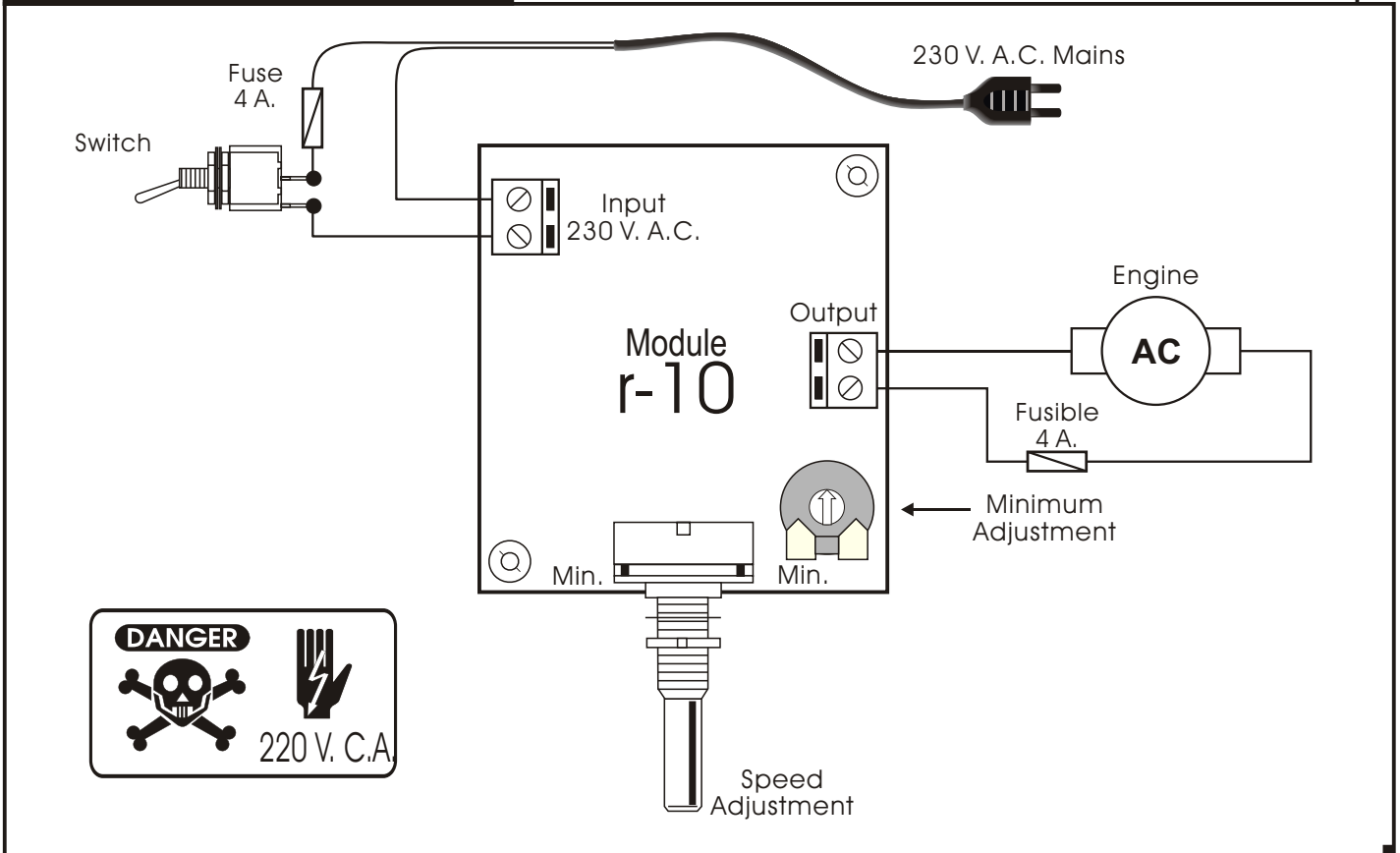

## HOW TO INSTALL THE CIRCUIT.

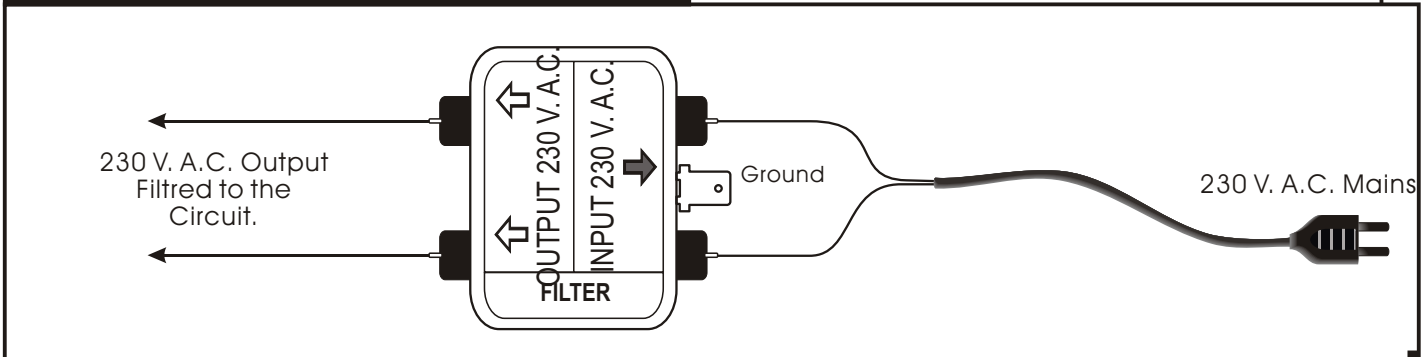

## TECHNICAL SUPPORT AND INFORMATION.

For any questions or more information:

By Fax. (24h.) +34.93. 432.29.95

By E-Mail: [cebek@cebek.com](mailto:cebek@cebek.com)

Keep you invoice. For any repairing could you send this with module. Else, the module will lost the warranty.

**MORE 300 MODULES.**

All the module's CEBEK have **3 years of total warranty** in thechnical repairing, and spares from the date of buy.

CEBEK is trade make of FADISEL S.L. more than 300 module's are available in stock for any purpose **request our CATALOGUE**, or visit our Web.

[Http://www.sakma.com/CEBEK](http://www.sakma.com/CEBEK)

**WARRANTY**

**3 YEARS**