



The I-57 module is a sequential command with 8 relay outputs with manual or automatic go forward or backward and with independent adjustment for connection and disconnection times. It allows to consecutively connect, with or without disconnect the previous one as well as to reset the sequence from the first or the last output, or to select the outputs number of the sequence. Thanks to the I-58 and I-59 modules you can increase it up to a maximum of 256 channels. It includes indicators Leds and it can be adapted on our RAIL DIN ref. C-7590.

**TECHNICAL CHARACTERISTICS**

Voltage.....12 V. D.C.  
 Minimum/maximum Consumption.....10 mA / 450 mA.  
 Maximum admissible load by the relay.....5 A.  
 Output connection time.....Min. 1 sec. / Max. 240 min.  
 Disconnection time between outputs.....Min. 0,3 sec. / Max. 58 sec.  
 Up, Down and Reset Input signals.....5 V. D.C., (Flanco de Bajada).  
 Protection against inversion polarity, (P.I.P.).....Yes.  
 Dimensions.....107 x 132,5 x 30 mm.

**INSTALLATION.**

**POWER SUPPLY.** The I-57 circuit had to be supplied by a 12 VDC power supply. Then, we recommended you the FE-123 power supply which has been developed to perfectly answer to the circuit needs or a 12 V batteries for mobile applications. Install a fuse and a switch as it is indicated in the drawing. Both are obligatory to guarantee a correct protection of the module as well as for your own safety as it is required by the "CE" marking. Connect the positive of the power supply to the positive terminal indicated in the wiring map, then connect also the negative of the power supply to the negative terminal indicated in the circuit. The distance between the power supply and the module as to be as short as possible. Verify that the assembly has been correctly done.

**OUTPUT. CONNECTION OF THE LOAD.** I-57 module's outputs are controlled by relays, devices electrically insulated from the rest of the circuit, they allow any load until 5 A, as maximum consumption. The relay is not a component supplying voltage but its function is limited to accept or deny the voltage passage like a standard switch. For this reason, you have to supply the load through this device. The relay has three output terminals: The normally open quiescent (NO), the normally closed quiescent (NC) and the common. Install it between the Common and the NO as it is indicated in the Fig.1. For the inverse function you have to place the load between the NC and Common.

Fig. 1. How to connect the Load.

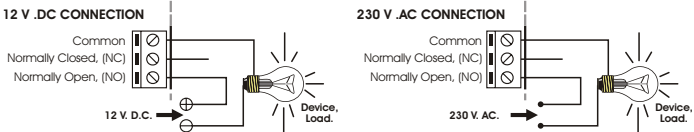

**INFORMATION ABOUT THE OUTPUT.** During the operating mode and according to its load, it could happen a fluctuation or an incorrect working of the output. In such case, you have to install an anti-spark circuit (100 nF/400V Type X2 Capacitor and 47W. 1/2W resistor) between both contacts of the used relay, as it is indicated on the drawing.

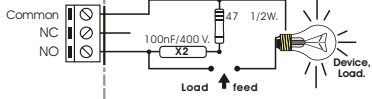

**TO PROGRAM THE OUTPUTS Nº OF THE SEQUENTIAL.**

**TO ESTABLISH OUTPUTS.** The I-57 module can be an autonomous 8 channels sequential or a control module for a wider system, with a maximum of 256 outputs that you can obtain adding extension modules (I-58 is a 4 channels extension module or the I-59 which is a 8 Channels extension). See the corresponding instruction manual.

The obtained sequential, with or without extensions, has to be programmed because alone it can not know the outputs quantity to control. See the "General Wiring Map" paragraph and you check that the circuit offers 2 switches batteries composed by 8 Dips switches and indicated as "control" and "Relays". Thanks to the "Relays" switches you can program on the module the number output number from which the cycle has to be restarted. The outputs number selection will be done in binary mode, through the combination of the 8 micro switches. If you place any of these switches in ON position, its value will be "1" and if you place it in OFF, their value will be "0". The micro switch "1" corresponds to the bit with lower weight (LSB), and the higher weight corresponds to the micro switch 8 (MSB)

Fig. 2. Binary value for microswitches according their position.

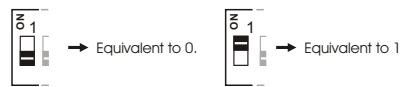

On the table (Fig.3), you can see the correspondence between ten numbers from 0 to 256 and their respective binary code. For instance, if you want that the I-57 only operates with 5 outputs, and when it reaches the Nº5 it reset the

Fig. 3. Correspondence table Ten - Binary.

| Outputs Nº | 1 | 2 | 3 | 4 | 5 | 6 | 7 | 8 |
|------------|---|---|---|---|---|---|---|---|
| 1          | 0 | 0 | 0 | 0 | 0 | 0 | 0 | 0 |
| 2          | 1 | 0 | 0 | 0 | 0 | 0 | 0 | 0 |
| 3          | 0 | 1 | 0 | 0 | 0 | 0 | 0 | 0 |
| 4          | 1 | 1 | 0 | 0 | 0 | 0 | 0 | 0 |
| 5          | 0 | 0 | 1 | 0 | 0 | 0 | 0 | 0 |
| 6          | 1 | 0 | 1 | 0 | 0 | 0 | 0 | 0 |
| 7          | 0 | 1 | 1 | 0 | 0 | 0 | 0 | 0 |
| 8          | 1 | 1 | 1 | 0 | 0 | 0 | 0 | 0 |

Fig. 4. How to program Outputs nº.

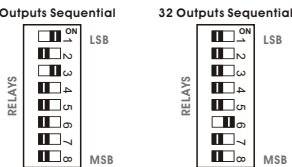

module, you have to program the Dip switches with the binary code 101. At the opposite, if you have incorporated several extension modules to control 32 outputs, the binary code will be 11110. See the fig. 4.

**CONTROL FUNCTIONS.**

Thanks to the "Control" battery you could configure different module's operating options.

**OPERATING MODE.** The I-57 allows a manual operating mode, with go forward through impulses, or an automatic operating mode through an internal adjustable oscillator with different time scales.

**MANUAL OPERATING.** To select the Manual Operating Manual, you have to place the Micro switch 1 from the "Control" battery in ON position. The Mode Led will remains light off. The module offers two inputs, go forward "UP" and go backward "DOWN". Inputs will be activated by fianco de bajada. To excite them, you can use free potential contacts as push buttons, relays, switches, etc... or an external Clock.

If you use an external clock, make sure that its signal level is 5 V DC. If you don't supply the clock generator device with the same power supply than the I-57 module, you have to join together negative terminals of both circuits. If you use the same power supply to supply both circuits, this connection will not be necessary. If you use free potential contacts as push buttons, you have to connect one to each input ("up" and "Down"). Use quality push button to be sure to obtain a correct module's operating mode.

For the installation, you have to respect the inputs polarity and the cable length has to be as short as possible. If the distance is superior to 50 cm, you have to use shielded cable and to connect the braid to the screw corresponding top the ground symbol (negative). The maximum distance being 2 meters. See

**CONTROL FUNCTIONS.**

**AUTOMATIC OPERATING.** To select the automatic operating mode, you have to place the micro switch 1 from the "control" battery in OFF position. The module will done the sequence in a go forward and cyclic, depending on the operating times adjustment. The Mode Led will light on.

Each step in the automatic sequence is composed by the ON time, corresponding to relays' activation time, and the OFF time, assigned to the interval without connection between the activation of the previous relay and the following.

The circuit is composed by two variable resistors, ON and OFF to adjust both times. Through micro switches 5, 6, 7 and 8 from the "control" battery you have to select the timing scale to establish adjustment margins for ON time, allowing an adjustment between different time jumps. See the Fig. 5.

The OFF time will only be determined by the OFF variable resistor, with a minimum adjustment of 0,3 sec and a maximum of 58 sec.

**NOTE.** Changes done on times will only be applied by the module on the following relay jump, till you done a Reset.

Fig. 5. Times Selection.

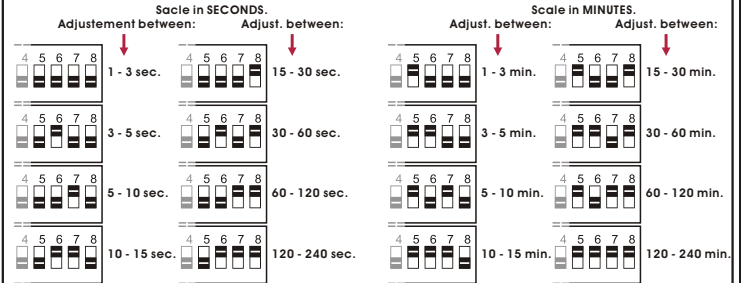

**DUAL / SIMPLE TIMES.** If you need to separately control relays' connection and disconnection time, you have to place the micro switch Nº4 in ON position. At the opposite, if you place the micro switch Nº4 in OFF position, you will not have OFF time, and the following relay will be activated after the disconnection of the previous one.

**NOTE.** Changes done on times will only be applied by the module on the following relay jump, till you done a Reset.

**TO GO FORWARD ON ONE OR TWO WAYS.** You can configure the module to go forward on a single way from left to right, with a restart of the sequence after the last programmed relay. Or to establish a go forward with backward, and after the last relay of the sequence, it continues go forward in opposite way up to reach the first relay, then restarting the cycle from the beginning.

Placing the micro switch Nº 3 in OFF position, you will select a single go forward and the Function Led will remain light off. At the opposite, if you place the micro switch Nº 3 in ON position, you will select a go forward and backward. The Function Led will remain light on.

**NOTE.** The I-57 will not recognize a change in this function, till you restart the sequence or you Reset it.

**INDIVIDUAL OR COLLECTIVE SEQUENCE.** Place the micro switch Nº2 in OFF position for an individual sequence. For a collective sequence place it in ON position.

The function of the individual sequence is to connect a relay, disconnecting the previous one.

The collective sequence connect relays one by one, without disconnecting the previous.

**NOTE.** We recommend you to do changes in this function with the power supply disconnected. Operating, the first sequence after a change does not correctly operate.

**GENERAL WIRING MAP.**

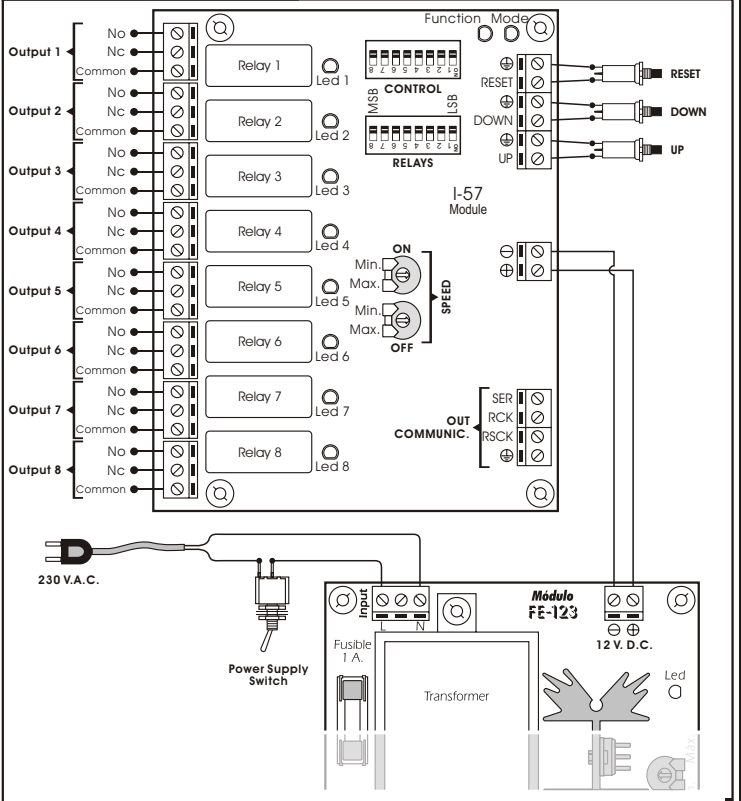

**TECHNICAL INQUIRIES.**

For any questions or more information:  
 By Fax: (24h.) +34.93.432.29.95 By Mail: C/ Quetzal, 17-21, Entlo. 2º (08014) BARCELONA - SPAIN.  
 By E-Mail: sat@cebek.com  
 Keep you invoice. For any repairing could you send this with module. Else, the module will lost the warranty.

MORE! **CEBEK'S** All the module's CEBEK have 3 years of total warranty in technical repairing, and spares from the date of buy. CEBEK is trade make of FADISEL S.L. more than 300 module's are available in stock for any purpose request our CATALOGUE, or visit our Web site

**GARANZIA ANDS 3 ANNI TOTAL ANNI WARRANTY**