



DTMF-01 DTMF GENERATOR / EMITTER.



The DTMF-1 module reproduces on a 5 V DC output, DTMF tones corresponding to the digits 1 to 9, * and #, from the supplied keyboard.

This function will allow it to generate control sequences on DTMF remote receivers, including also special access controls for Cebek DTMF receivers, being completely compatible. It includes a memory with a capacity for 10 digits or tones, when it is activated, it will insert and automatically reproduce it, like a predetermined number on each pressed digit. It can be installed on a DIN rail Ref. C-7563.

TECHNICAL CHARACTERISTICS.

Voltage	12 / 24 V. DC.
Min./max. Consumption	20 / 50 mA.
D.C DTMF Output.	0,4-0,8 V. DC
DTMF Output, (Impedance)	5 K ohms.
Memory Capacity/password.	1-10 tones.
Memory's life duration.	100.000 cycles / 100 years of años de retention.
Protection against the polarity inversion.	Power supply input.
Keyboard dimensions.	64 x 51 mm.
Main board Dimensions.	72 x 53,75 x 15 mm.
Connection cable between main board and keyboard.	190 mm.

POWER SUPPLY and INSTALLATION.

POWER SUPPLY. The DTMF-1 circuit is composed by 2 independent power supply inputs with a common negative, one at 12 V DC and one at 24 V DC. For a correct module's operating mode, you have to select a voltage among these two possibilities, and do never use both at the same time. Then, if you select 12 or 24 V, you have to use a power supply correctly filtered. We recommend you to use a short circuit power supply with a low ripple level like our FE-103, which has been developed to perfectly answer to the circuit needs. Do never use basic power supply neither rectifiers to avoid to damage devices.

Note: Install a fuse and a switch on the mains power input, both are necessary for the module's protection as well as for your own safety, as it is required by the "CE" regulations. See the general wiring map.

INSTALLATION. The module's installation has to be done in a waterproof place, avoiding any contact between circuit and other metallic objects. The module can't be installed in place with a high humidity or temperature, or with the possibility to be in contact with liquids. The module's keyboard, specially recommended for inside applications is not waterproof. For these kinds of applications, we suggest you to use the FADISEL keyboard ref. C-5236, which can substitute the originally supplied one. All connections, as well as the complete read of this present instruction manual have to be done before to supply the module.

WIRING. In the wiring you have to respect the polarity of different inputs, and the length of the used cable as to be as short as possible (mainly for the DTMF connection). If the required distance is superior than 2m, or for places including many industrial atmospheres, you have to use shielded cable and to connect the braid to the corresponding screw indicated with the ground symbol (negative). For the power supply input (power), you have to use parallel cable with a maximum length of 2 m.

DTMF Emitter-Receiver connection. The DTMF output offers a signal between 0.4 and 0.8 V DC, which is modulated to the frequency corresponding to each DTMF code. The connection between Cebek DTMF emitter and receivers is done connecting the OUT output of the emitter to the IN input of the corresponding DTMF Clema. The ground terminal of both clemas has to be also connected between both modules if they are supplied with different power supplies. If modules are supplied with the same power supply, it is not necessary to connect both grounds.

Fig. 1. Connection between Emitter and DTMF Receiver.

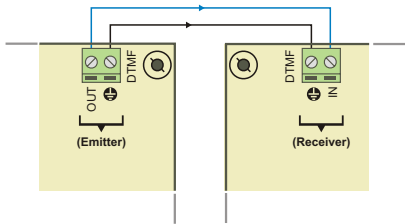

OPERATING MODE.

INDICATORS. There are four indicators leds in the circuit, and each one can display several functions.

Led Pwr. (Red). It is maintained lighted when the module is supplied.

Led Tone. (Green). It will light during the sending of a DTMF tone.

Led Prg. (Red). It will indicate different functions. It will light with a constant intermiffence when the module is in program mode. If it is permanently light, without any intermiffence, it will indicate the activation of the function: automatic password. It will be light off when this function is not activated or if the module is not in program function.

Led Key. (Yellow). It indicates, through its lighting, the correct pulse of any digit from the keyboard.

OPERATING MODE. Each time you press a digit; the circuit will recognize it and generate the corresponding DTMF tone, sending it through the output. If you maintain pressed a digit, the tone is maintained till you release it. The generation of different DTMF tones remains inscribed to the digits of the module, 0 to 9, * and #.

When you press two digits at the same time, the module will only generate a tone corresponding to the digit which has been firstly closed; ignoring any other order on the keyboard till the previous sending is finished. This characteristic has to be considered for the operating modes with automatic password; then you have to wait the Led Tone is stopped, before to press a new digit.

To adjust the DTMF output level. According to the adjustment of the variable resistor inserted into the circuit, indicated as Signal, you can vary the level of the DTMF output signal.

SPECIAL FUNCTIONS. The circuit includes different controls allowing it to accede to these special functions, or to make easier the program process with Cebek DTMF receivers.

Fig. 2. Fast Access Commands for Emitter's special functions.

	Step 1	Step 2	Step 3
Automatic Password (Deactivation) →	# + 0	-----	-----
Automatic Password, (Activation) →	# + 1	-----	-----
To program Emitter Password →	# + 2	Password	⊗
To program Receiver Password →	# + 4	Password	⊗
To program Relays timing →	# + 5	n° Relay	Relay Tim.

To program the Emitter's Password. The DTMF-1 includes a memory offering the possibility to store a sequence till 10 tones as maximum. After, this memory or password, can be automatically inserted by the circuit previously to each pulse on the keyboard.

To record the memory or the password, you have press at the same time the "#" and "2" digits. If the operation is correctly done, the module will indicate the entrance on the program mode through the intermiffence of the Led Prg.

OPERATING MODE.

Then you can insert one by one, pressing the corresponding digit, all different tones to store. Finally a pulse on the "#" digit, will store all introduced tones in the emitters memory. This storage will be indicated through the Led Prg with a fastest intermiffence than the previous one.

If the memory capacity is overcome (10 tones), if you introduce a tone different than digit 0 to 9, or if you don't press the "#" digit after the code, or if you wait more than 5 sec between pulse and pulse, the circuit will cancel the recording and leaving the program mode without making any change on the memory. This situation will be indicated by the absence of the mentioned fast intermiffence for the confirmation.

Automatic Password. Cebek DTMF receivers including other DTMF receivers (manufactured by other companies), offer a security code (password) for the access, which has to be send to a receiver previously to a tone or an activation sequence. The emitter includes a function to avoid for each operation that you have to do, to manually pulse the password on the keyboard, generating it automatically when you press any digit.

The activation of this automatic password is obtained pressing at the same time the "#" and "1" digits. The Led Prg will light till this function is activated.

To deactivate this automatic password, you have to press at the same time the "#" and "0" digits.

During the activation of this function, you can not program others Cebek receivers through fast Access Commands, but through specific program codes (See the receivers' instruction manual).

To program the password on Cebek DTMF receivers. Cebek receivers can operate with a password. For its security, once the password programmed on the receiver, this one doesn't accept any operation on it, concerning control or program functions, if you don't previously insert the mentioned code. Do not forget that if you don't remember or don't correctly introduce this security code, you could not operate with the receiver, and you can deactivate it. Then you should send back to our distributor for a complete system's reset.

For this reason, we suggest you to pay attention during the record operation, strictly respecting the instructions described into the corresponding supplied manual. Cebek can not be responsible for the receivers' blocking due to such reasons, being excluded of the product's warranty.

The Automatic Password's record process has to be done deactivating, if it is activated, the emitter's automatic password ("#" and "0"). Then, you can program the receiver. If this one is protected by a previous password, you have to firstly introduce it and then to press the program code of the receiver's password ("#" and two times "9" digit). If the receiver is not protected through a password, you can directly use the fast Access Command, pressing "#" and "5" digits. In both cases, the correct access to the receiver's program mode will be indicated through a fix lighting of the Led Prg.

Then, you can introduce one by one, pressing the corresponding digit, the different tones to store. Each pulse has to be clearly done, avoiding to press at the same time two digits and seeing that the emitters Led Key is correctly lighted with each pulse.

Finally, a last pulse on the "#" digit, will store on the receiver's memory all introduced tones, and automatically activating its password (Less Pass lighted without intermiffence).

If you overcome the maximum capacity of the memory (10 tones), if you don't press the "#" digit after the code, or if you wait more than 5 sec. between pulse and pulse, the circuit will cancel the record, leaving the program mode without making any change on the memory.

To program the relays timing in Cebek DTMF receivers. The fast access command ("#" and "5" digits) allows to accede to the configuration of each receiver outputs connected to the DTMF-1, with a standard or timed operating mode, if the receiver is not protected by a password; in such case you have to firstly introduce its required code and then the receiver codes for outputs ("#" and two times the "0" digits). A correct access to the program mode for outputs will be indicated by the receiver's Led Prg lighting (without intermiffence).

When the Led Prg I slighed, you have to press the number of the output that you want to configure (from 1 to 8), and then a number composed by three digits. This number from 001 to 250 will assign the number of seconds, that after each activation, the output will be maintained timed. If the introduced number is 000, the output will operate in flip-flop mode. If the introduced number is superior than 250, the receiver will be automatically programmed with the maximum value (250).

GENERAL WIRING MAP.

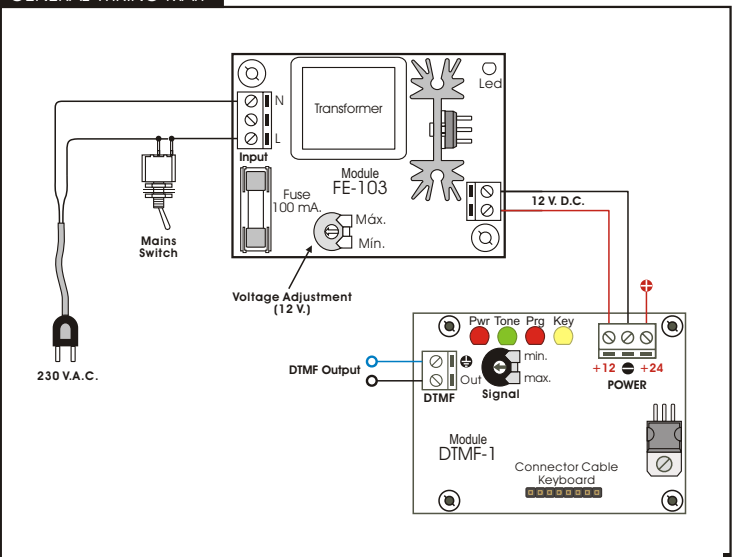

TECHNICAL SUPPORT AND INFORMATION.

For any questions or more information:

By Fax. (24h.) + 34.93.432.29.95 **By Mail:** C/ Quetzal, 17-21, Entlo. 2º (08014) BARCELONA - SPAIN.

By E-Mail: sat@cebek.com

Keep you invoice. For any repairing could you send this with module. Else, the module will lost the warranty.

All the module's CEBEK have **3 years of total warranty** in thechnical repairing, and spares from the date of buy. CEBEK is trade make of FADISEL S.L. more than 300 module's are available in stock for any purpose **request our CATALOGUE**, or visit our Web site www.cebek.com

